

PLEASE NOTE: DIMENSIONS MAY VARY BY PLUS OR MINUS 3% DUE TO THE ROTATIONAL MOULDING PROCESS.

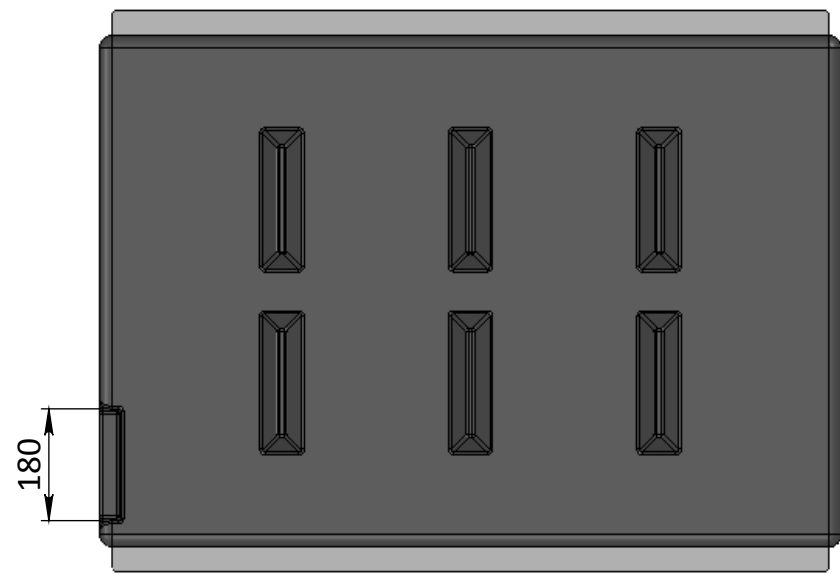

TOP VIEW

WATER TANKS ARE MADE FROM FOOD GRADE POLYETHYLENE

DIESEL TANKS ARE MADE FROM DIESEL GRADE POLYETHYLENE

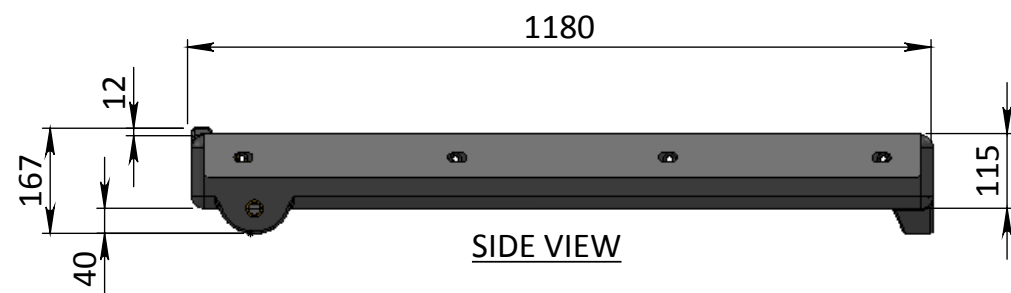

SIDE VIEW

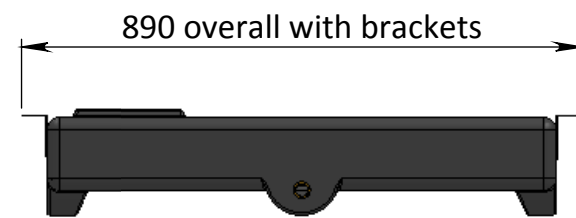

END VIEW

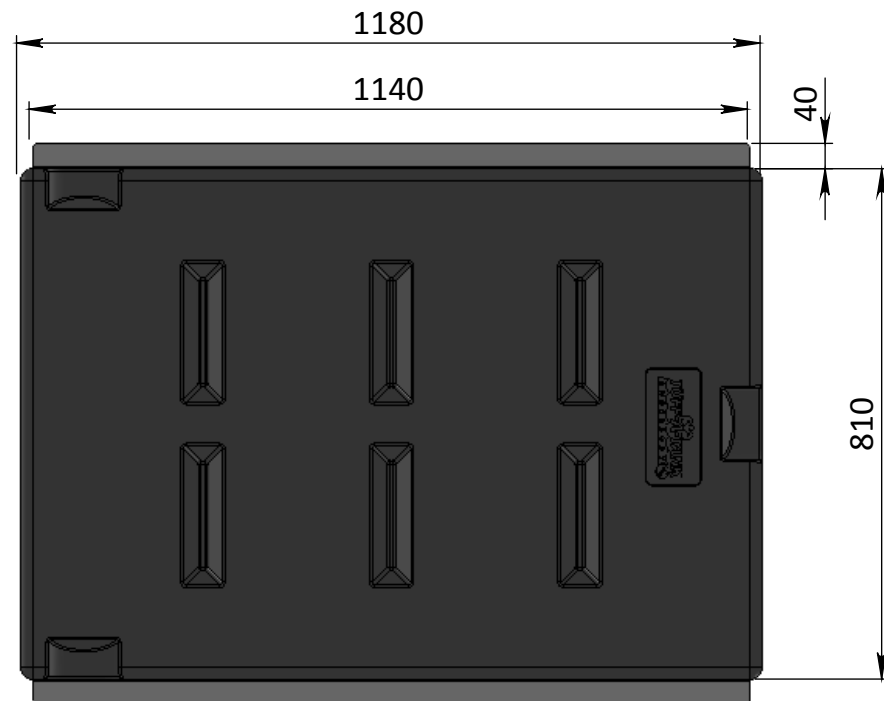

UNDERNEATH VIEW

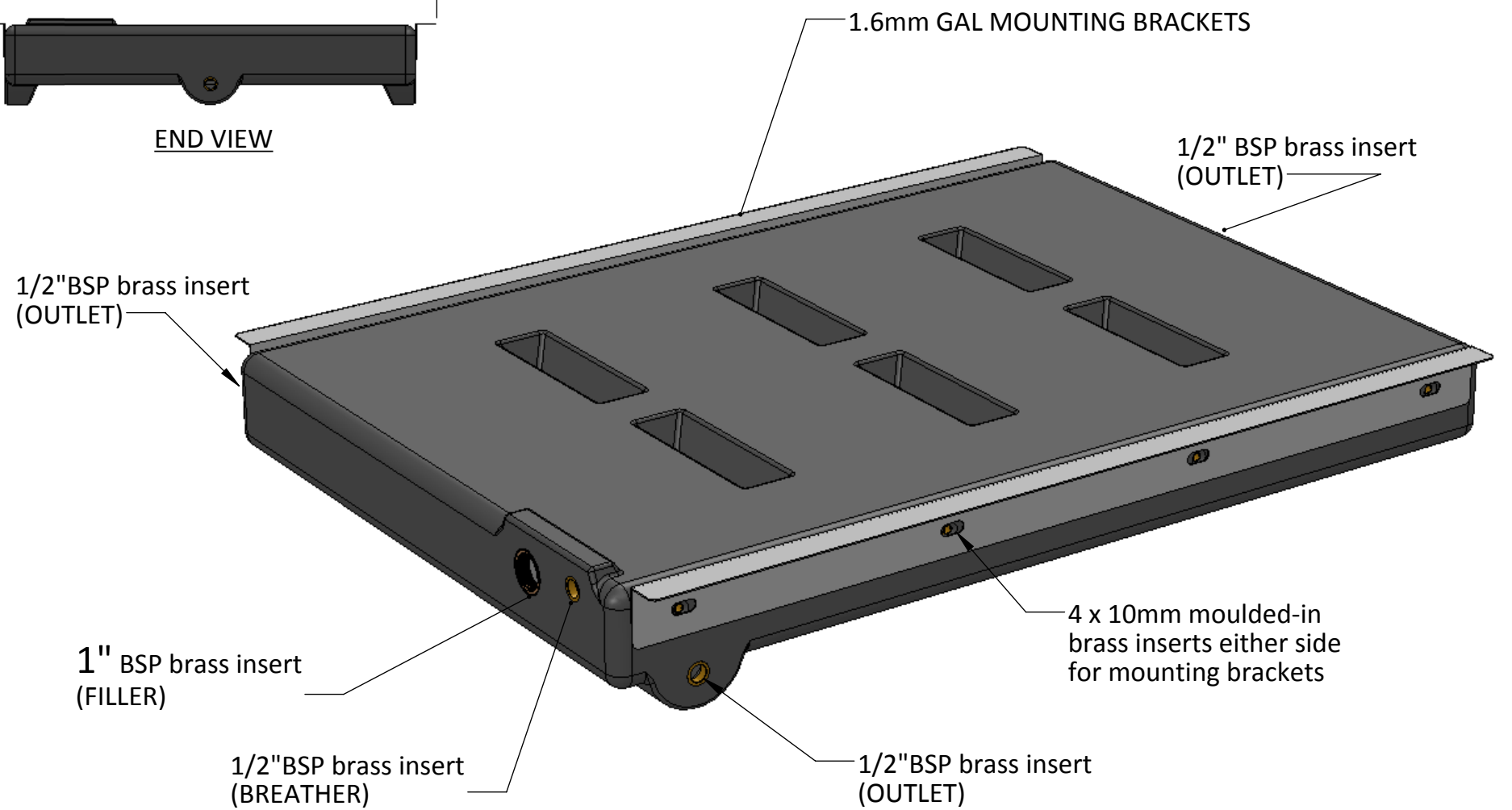

REV	DATE	BY	DESCRIPTION	GOUGH
A	03.12.14	DH	UPDATED DESIGN AS OF DECEMBER 2014	
REVISION				APPROV.



A.C.N. 010 028 547
 Gough Industries Pty. Ltd.
 833 Ingham Road
 Bohle, Townsville
 P.O. Box 7570, Garbutt BC, Qld. 4814.
 Telephone 07 47747606
 Facsimile 07 47747608

80L SLIMLINE WATER TANK

Signature	Date	SCALE	A3	Gough Plastics Drg. No.	A	REV
D.HOLLIER	03.12.14			BOX405.8080-01		
DRN. CHK	B.RITCHIE	03.12.14	S:\Products\Domestic\Underbodies\80L Slimline\			