

Bulkezy Information Sheet



call **1800 069 805**

www.gough.com.au

Email: sales@gough.com.au

833 Ingham Rd, Bohle
TOWNSVILLE

Ph: (07) 4774 7606

Fax: (07) 4774 7608

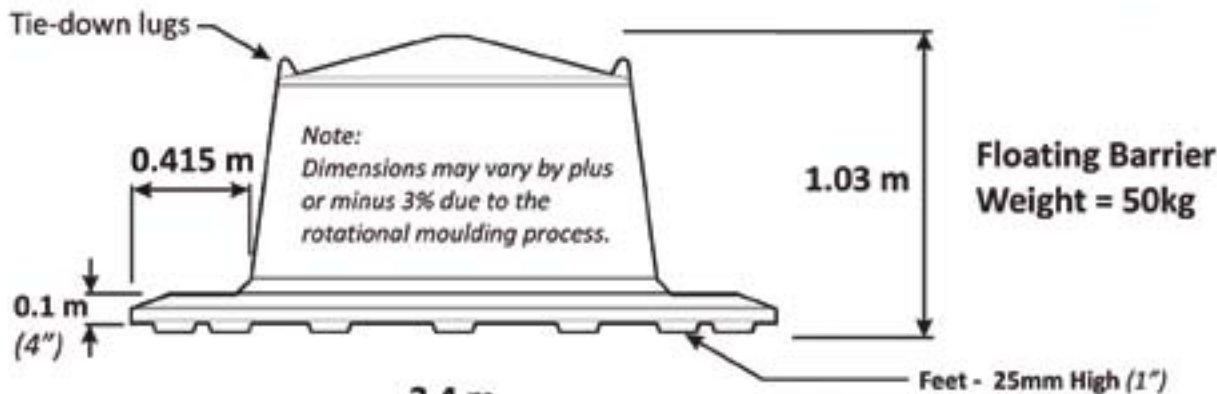
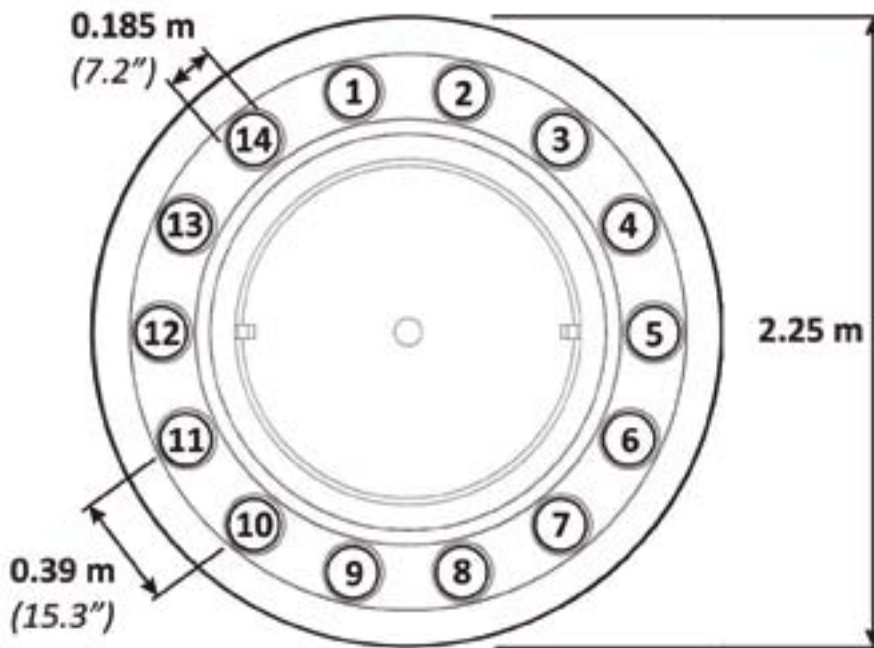

**Floating Barrier
Weight = 50kg**

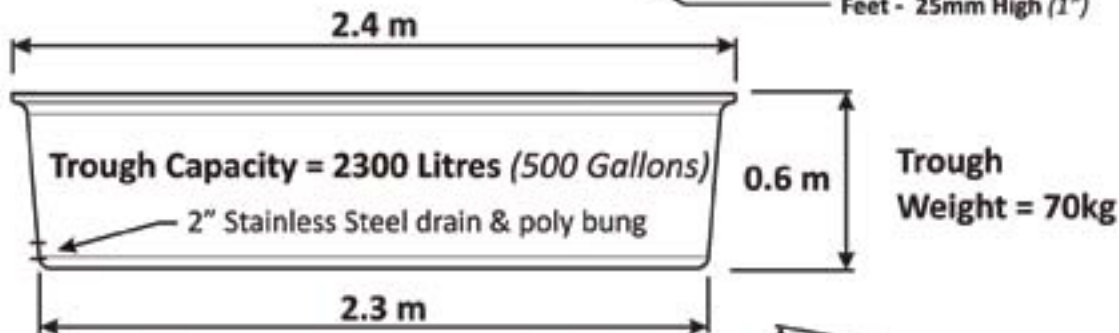

**Trough
Weight = 70kg**



**5 x Unit
Freight Pack
Weight = 600kg**

2.1 m

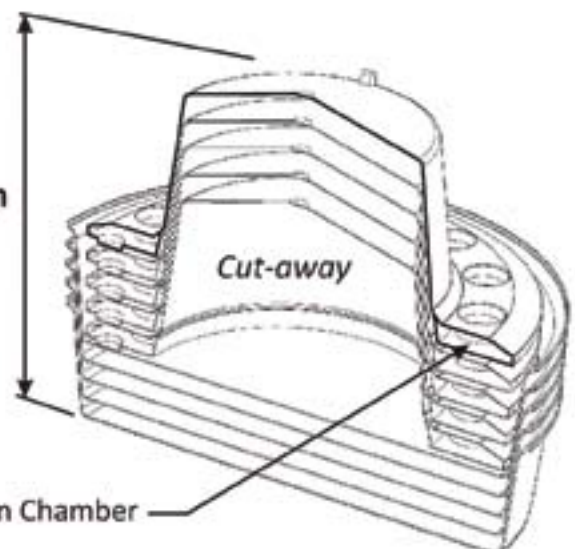

Sealed Floatation Chamber