

A	02.12.11	DH	FIRST ISSUE		 <p>Gough Industries Pty. Ltd. 833 Ingham Road Bohle, Townsville P.O. Box 7570, Garbutt BC, Qld. 4814. Telephone 07 47747606 Facsimile 07 47747608 A.C.N. 010 028 547</p>	DRAWN	Signature	Date	LICKROOF - FULLY ASSEMBLED				
						DRN. CHK	D.HOLLIER	02.12.11					
						ENGINEER							
						ENG. CHK							
No.	DATE	BY	DESCRIPTION	GOUGH	<p>This drawing remains the property of Gough Industries Pty. Ltd. It is subject to Gough Industries Pty. Ltd.'s recall and must not be reproduced in part or whole or it's contents divulged to third parties without prior written approval from Gough Industries Pty Limited.</p>	Eng. APPROVAL			SCALE	A3	Gough Plastics Drg. No. FFAR800.2400.01-01	A	REV
			REVISION	APPROV.									

S:\Products\Rural\Development\LickRoof\Fram Drawings\

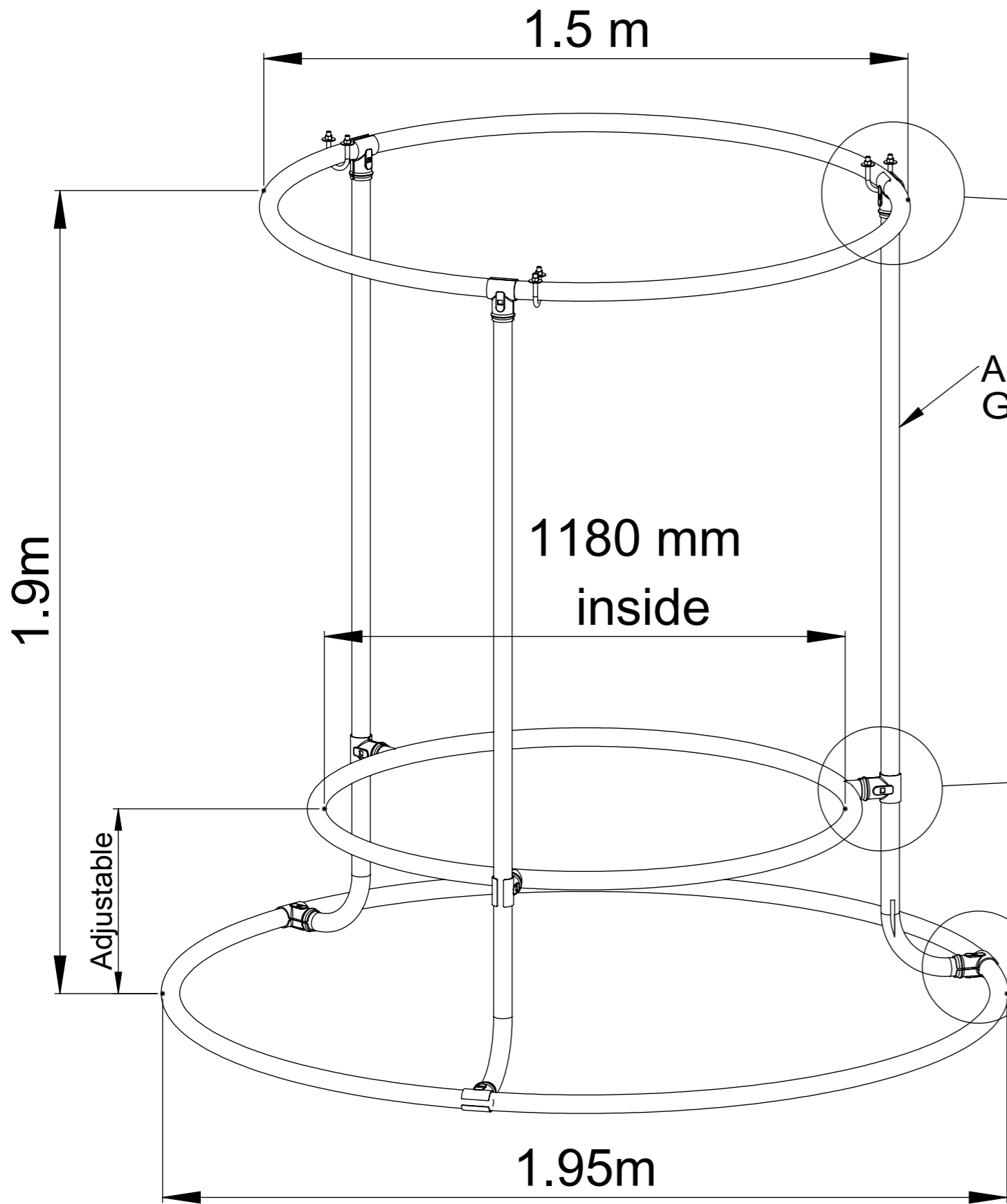

STEP 4.

PLACE ROOF ON TOP AND U-BOLT BY PUSHING U-BOLTS THROUGH THE PRE-DRILLED HOLES FROM UNDERNEATH. PLACE WASHERS ON AND TIGHTEN NUTS FROM ABOVE.

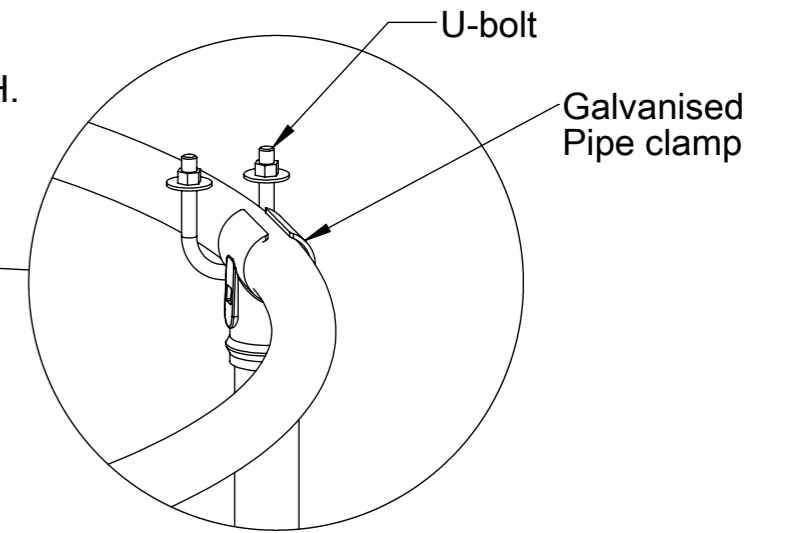

All steel is 42.4mm diameter Gal Pipe (3.2mm wall thk.)

STEP 3.

CLAMP MIDDLE SIZED RING TO TOP OF ALL 3 LEGS

Galvanised Pipe clamp

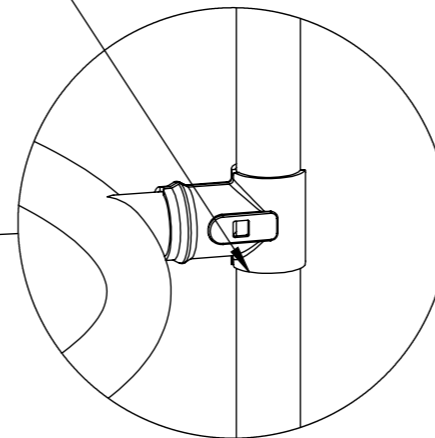

STEP 1.

CLAMP LEGS TO THE SMALLEST RING OVER THE 3 PIPE STUBS THAT STICK OUT. TOP OF CLAMP 500mm UP FROM GROUND LEVEL)

Galvanised Pipe clamp

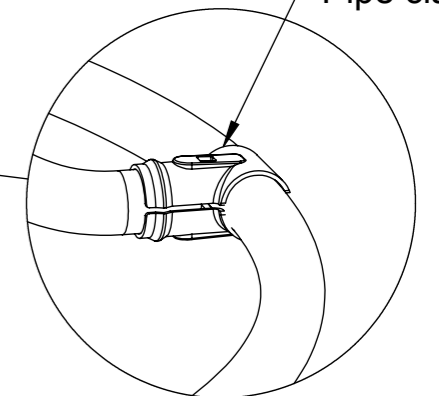

STEP 2.

CLAMP BOTTOM OF LEGS (HOOK END) TO LARGEST BASE RING AT GROUND LEVEL

A	02.12.11	DH	FIRST ISSUE	
No.	DATE	BY	DESCRIPTION	GOUGH
			REVISION	APPROV.



Gough Industries Pty. Ltd.
 833 Ingham Road
 Bohle, Townsville
 P.O. Box 7570, Garbutt BC, Qld. 4814.
 Telephone 07 47747606
 Facsimile 07 47747608
 A.C.N. 010 028 547

This drawing remains the property of Gough Industries Pty. Ltd. It is subject to Gough Industries Pty. Ltd.'s recall and must not be reproduced in part or whole or it's contents divulged to third parties without prior written approval from Gough Industries Pty Limited.

DRAWN	Signature	Date
DRN. CHK	D.HOLLIER	02.12.11
ENGINEER		
ENG. CHK		
Eng. APPROVAL		
		NO

LICKROOF - STEEL (GAL) FRAME

SCALE	A3	Gough Plastics Drg. No. FFAR800.2400.01-02	A	REV
S:\Products\Rural\Development\LickRoof\Fram Drawings\				

ROOFS NEST TOGETHER
FOR TRANSPORT
(Approx 40kg per roof)

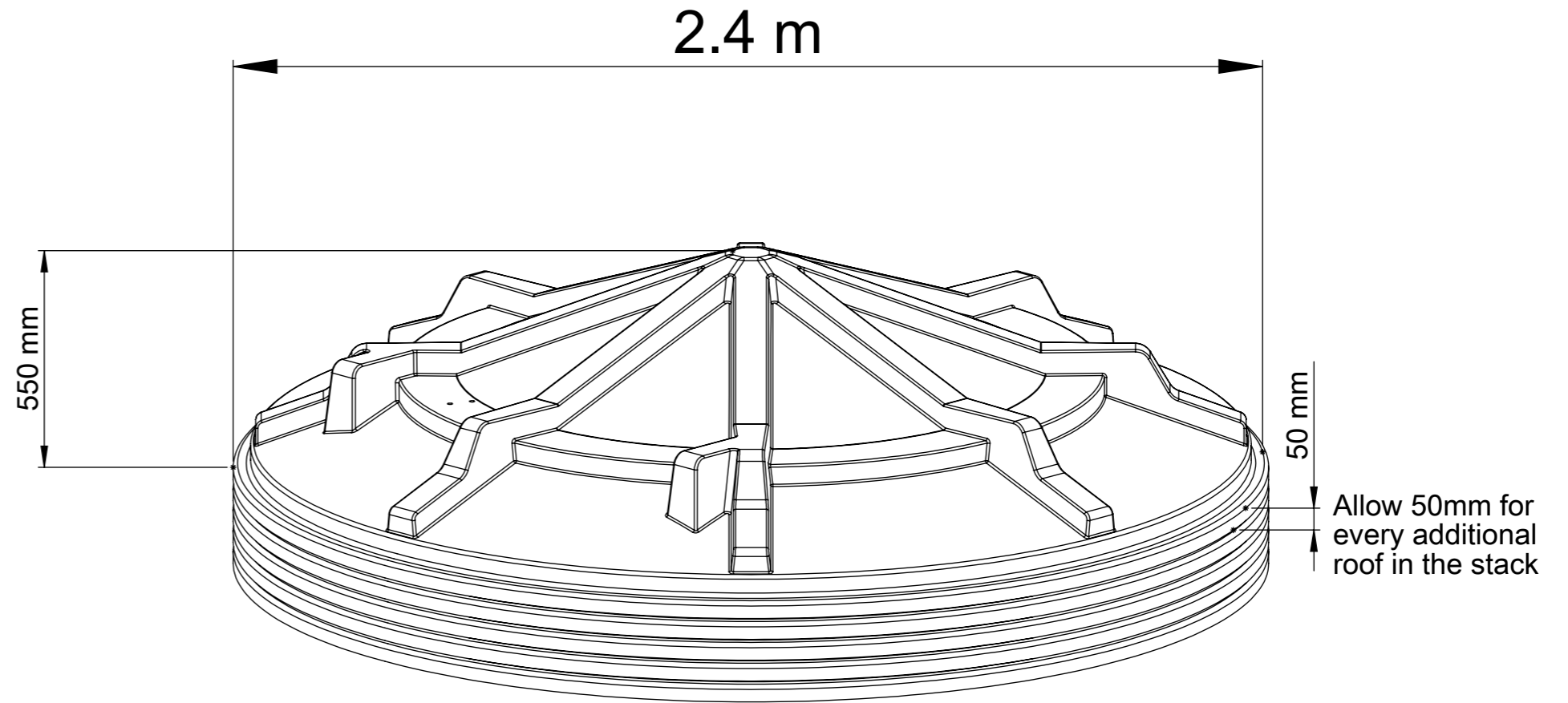

1.95 m

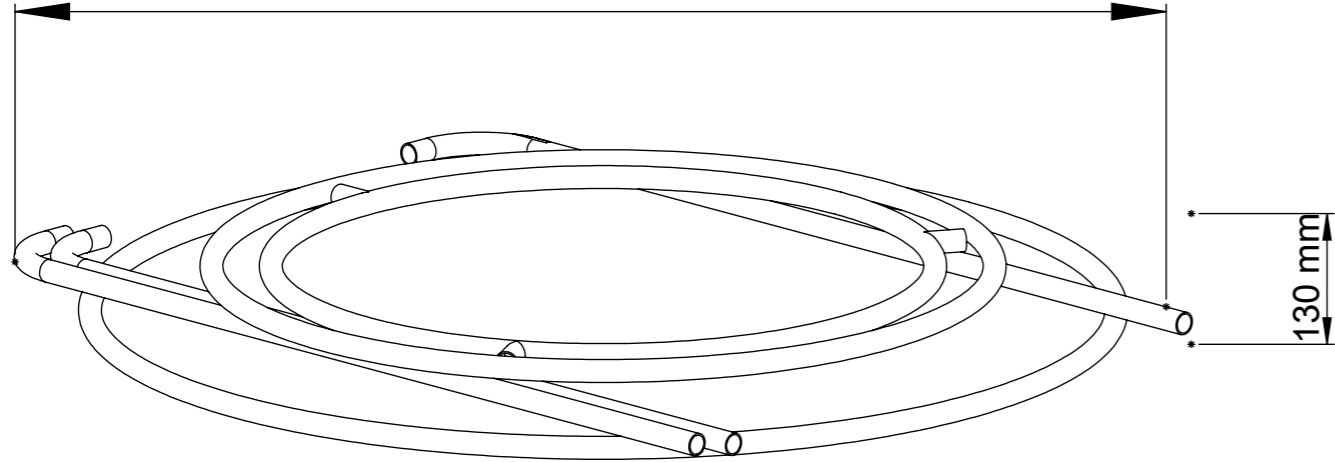

FRAMES FLAT PACK
FOR TRANSPORT
(Approx 68kg per frame)

TROUGHS NEST TOGETHER
FOR TRANSPORT

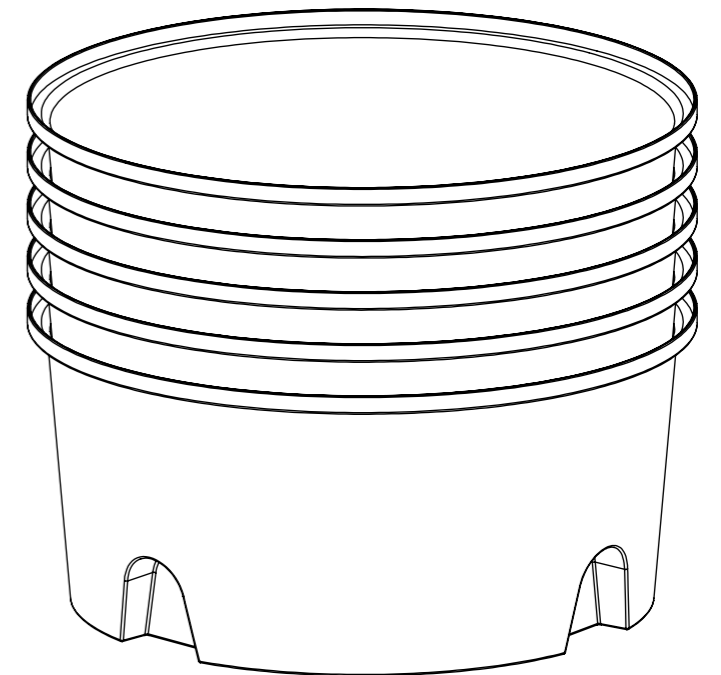

A	02.12.11	DH	FIRST ISSUE		 GOUGH PLASTICS Custom Rotational Moulders	Gough Industries Pty. Ltd. 833 Ingham Road Bohle, Townsville P.O. Box 7570, Garbutt BC, Qld. 4814. Telephone 07 47747606 Facsimile 07 47747608 A.C.N. 010 028 547	DRAWN	Signature	Date	LICKROOF - TRANSPORT DETAILS				
				DRN. CHK			D.HOLLIER	02.12.11						
				ENGINEER										
				ENG. CHK										
No.	DATE	BY	DESCRIPTION	GOUGH	This drawing remains the property of Gough Industries Pty. Ltd. It is subject to Gough Industries Pty. Ltd.'s recall and must not be reproduced in part or whole or it's contents divulged to third parties without prior written approval from Gough Industries Pty Limited.	Eng. APPROVAL				SCALE	A3	Gough Plastics Drg. No. FFAR800.2400.01-03	A	REV
			REVISION	APPROV.										

S:\Products\Rural\Development\LickRoof\Fram Drawings\